



DX Nd:YLF Series High Pulse Energy Nanosecond Lasers

www.photonix.com

Photonics Industries' DX Nd:YLF Series nanosecond lasers combine high pulse energies (up to 35 mJ) with a simple, rugged, and efficient form factor, all from one fully independent laser resonator. Dual Head configurations can go up to 70 mJ. The DX Nd:YLF Series uniquely fulfills both criteria of beam spatial mode TEM₀₀ ($M^2 < 1.2$) while achieving high millijoule-level pulse energies, enabling scientific applications for ultrafast pumping amplifiers or industrial applications such as in diamond microprocessing.



Features

- High pulse energy TEM₀₀ nanosecond laser
Up to 35 mJ, Green
- Two fully independent lasers, integrated into a Dual Head configuration available. Contact us.
Up to 70 mJ, Green
- Exceptional repetition rate control:
Single shot up to 10 kHz
- Multimode beam option available (see DM Series brochure)

Specifications – **DX Nd:YLF Series High Pulse Energy Nanosecond Lasers**, Nd:YLF GRN Models

	DX-527-25	DX-527-35
Beam and output specifications		
Wavelength ¹	527 nm	
Average power ²	38 W at 3 kHz	50 W at 3 kHz
Pulse energy	25 mJ at 1 kHz	35 mJ at 1 kHz
Pulse width	~90 ns at 1 kHz	~100 ns at 1 kHz
Pulse repetition rate ³	Single shot to 10 kHz	
Pulse-to-pulse stability ⁴	< 1% rms	
Long term power stability ⁵	< 0.5% rms	
Beam spatial mode ^{6a, 6b}	TEM ₀₀ M ² < 1.2	
Beam pointing stability	< 25 μrad	
Beam divergence	2 mrad ±15%	
Beam diameter, at exit	~1 mm	
Polarization ratio	Vertical; 100:1	
Operational specifications and system characteristics		
Interface	RS232, Ethernet, Software GUI, External TTL Triggering	
Warm-up time	< 5 minutes from standby, or cold start	
Electrical requirement	100-240 V AC	
Line frequency	50-60 Hz	
Ambient temperature	Ambient 15°C to 30°C (59°F to 86°F) Operating Range, Relative Humidity 90% Max., non-condensing	
Laser head Dimensions (LxWxH)	26 x 6.5 x 4.23 in	
Power supply Dimensions (LxWxH) ⁷	15 x 10.2 x 3.5 in	
Cooling system	Water-cooled	

- 351 nm wavelength option available on request. Contact us.
- Higher average powers available in a Dual Head configuration. Contact us.
- Lower pulse repetition rates (down to < 1 kHz) performance achieved by pulse energy capping.
- Measured at ambient temperature ± 2°C
- Measured over 8 hours ± 1°C
- Multimode beam option available (see DM Series brochure).
- M² values are optimized in ranges between either 1-5kHz or 5-10kHz based upon customer request. Contact us.
- Total width with rack mount option is 19 in. Please note height in rack units is 2U.

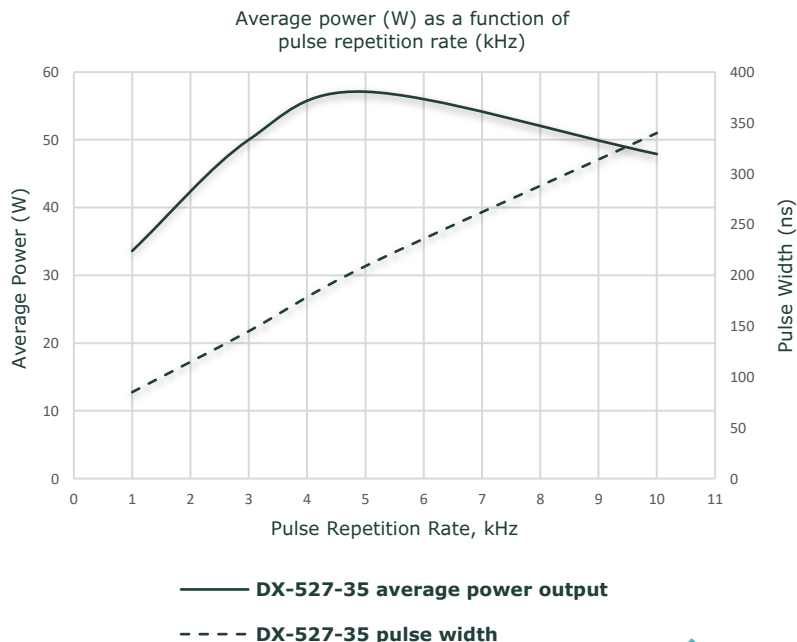

Dimensional Drawings

DX-527, 25-35 mJ

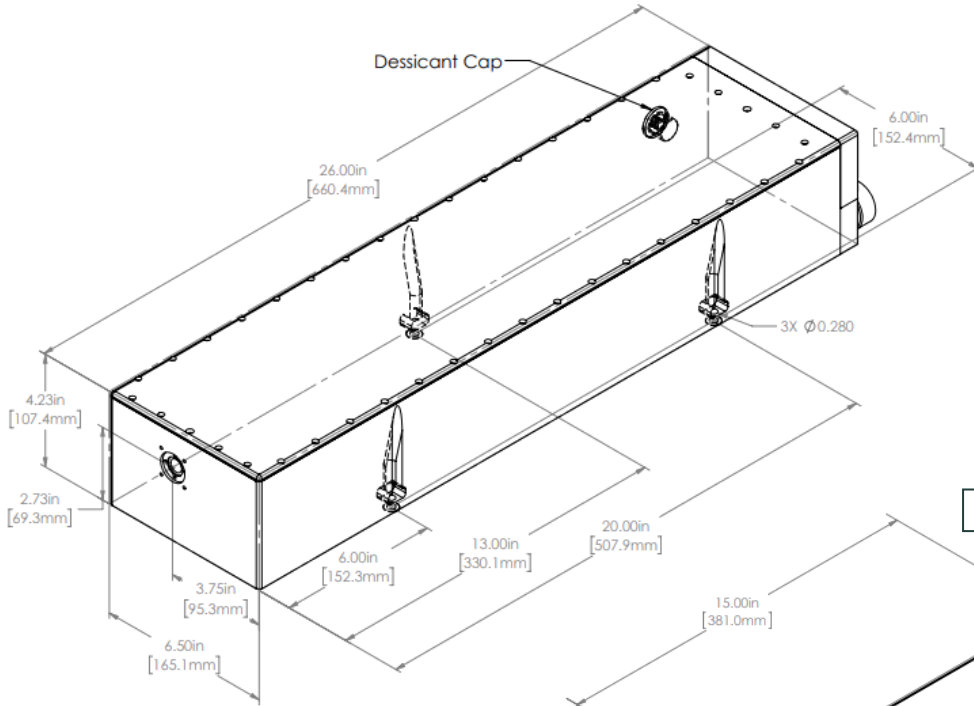

DX Nd:YLF Series Power Supply

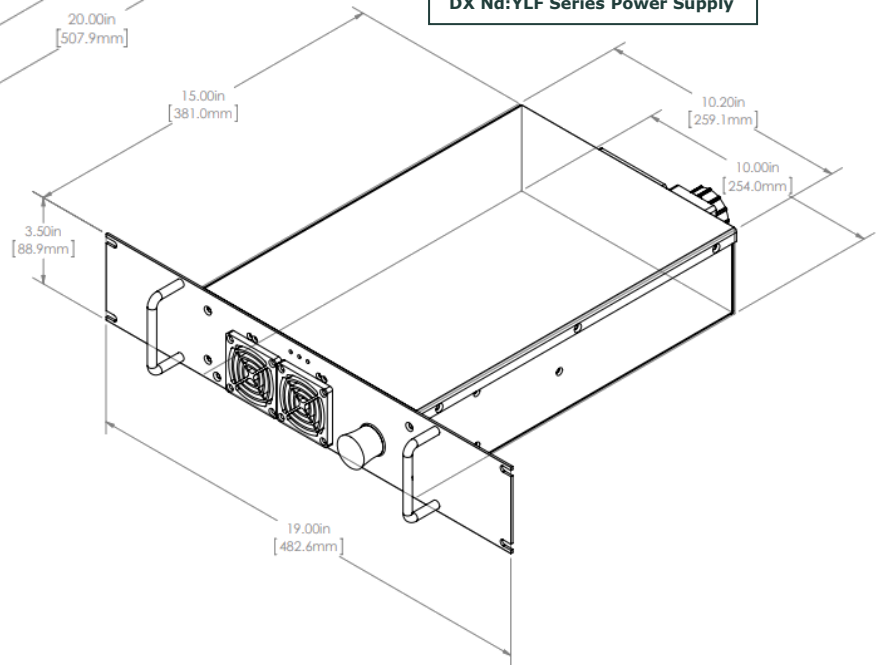

Photonics Industries DX Nd:YLF Series nanosecond lasers have a separate external power supply box, no longer requiring an external controller or utility module. The RF driver is located in the laser head, and all control electronics and connections for operation and control of the laser can be found on the back panel of the compact laser head.

Product specifications, characteristics, and dimensional drawings are subject to change without notice.

Photonics Industries conforms to provisions of US 21 CFR 1040.10 & 1040.11 and is made under one or more US patents listed below: 9,531,147, 8,817,831, 7,869,471, 7,346,092, 7,082,149, 7,079,557, 6,999,483, 6,980,574, 6,961,355, 6,842,293, 6,762,405, 6,690,692, 6,587,487, 6,584,134, 6,366,596, 6,356,578, 6,327,281, 6,246,707, 6,229,829, 6,108,356, 6,061,370, 6,028,620, 5,936,983, 5,898,717 and Pending Patents

Copyright © 2022 by Photonics Industries International, Inc.

Main Headquarters: 1800 Ocean Ave, Ronkonkoma, New York 11779, United States

Photonics Industries International is the pioneer of intracavity harmonic lasers and is at the forefront of developing, manufacturing and marketing a wide range of nanosecond, sub-nanosecond, picosecond and femtosecond lasers for industrial, scientific, defense, and medical industries. Check out our products and see how we can help you apply our lasers to your needs.

[Website](#) - [Products](#) - [Applications](#) - [Company](#) - [Contact](#) - [International Network](#)



光と人をつなぐ

Rayture Systems



レイチャーシステムズ株式会社

〒160-0006 東京都新宿区舟町7 ロクサンビル7F

TEL : 03-3351-0717 FAX : 03-3351-6771

URL : <http://www.rayture-sys.co.jp>

E-mail : laser@rayture-sys.co.jp